



Product: Curved Bench Solo

Description:

Solo bench unit for the Newton range, designed to be used as a standalone unit. Precast concrete. Internal Radius 4600mm.

Colour: Available in standard colours

- White: WH03, WH06
- Light Grey: LG01, LG02, LG05
- Dark Grey: BL02
- Black: BL03
- Buff: YL01
- Other colours available on request

Finish:

- Concrete: Light Acid Etched
- Timber: N/A
- Other finishes available on request

Fixing: Surface Fixed

Unit should be placed on finished surface, using appropriate lifting equipment, no additional fixing required.

Packing:

Banded & protected. 1 unit per pallet. Unit to be removed from the pallet before installation.

Standard Shipping:

Dedicated delivery or pallet service available by request

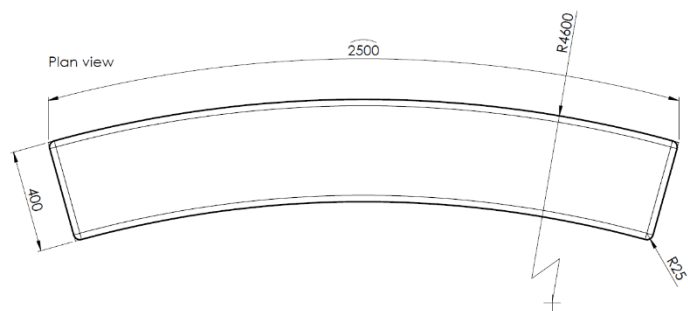
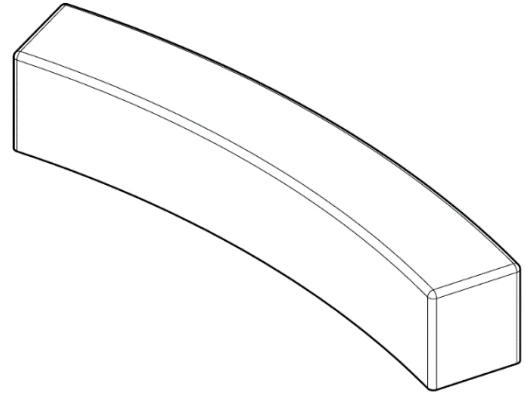

Side view

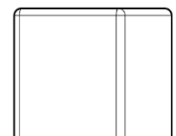

Technical Details:

- Length: 2500mm
- Depth: 400mm
- Height: 450mm
- Weight: 1030Kg