



### Product: Bench End (-25mm)

#### Description:

End bench unit for the Newton range, designed to be used in an arrangement. Precast concrete.

#### Colour: Available in standard colours

- White: WH03, WH06
- Light Grey: LG01, LG02, LG05
- Dark Grey: BL02
- Black: BL03
- Buff: YL01

Other colours available on request

#### Finish:

- Concrete: Light Acid Etched
  - Timber: N/A
- Other finishes available on request

#### Fixing: Surface Fixed

Unit should be placed on finished surface, using appropriate lifting equipment, no additional fixing required.

#### Packing:

Banded & protected. 1 unit per pallet.  
Unit to be removed from the pallet before installation.

#### Standard Shipping:

Dedicated delivery or pallet service available by request

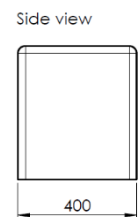
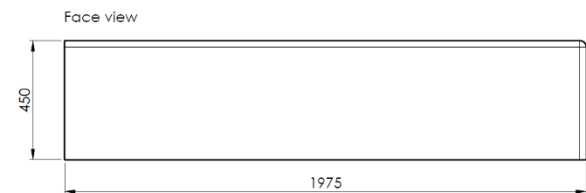
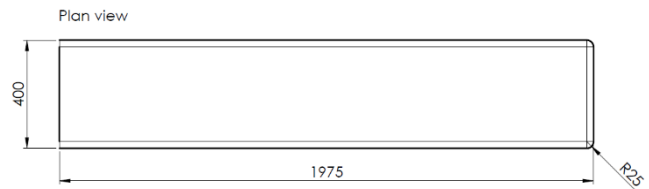
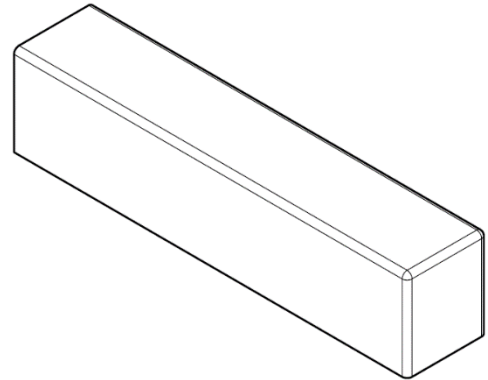

#### Technical Details:

- Length: 1975mm
- Depth: 400mm
- Height: 450mm
- Weight: 850Kg