



## Range: Stanton

## Product Specification Sheet

### Product: Curved Mid

#### Description:

Mid unit for the Stanton range, designed to be used in an arrangement. Precast concrete. Internal Radius 1200mm.

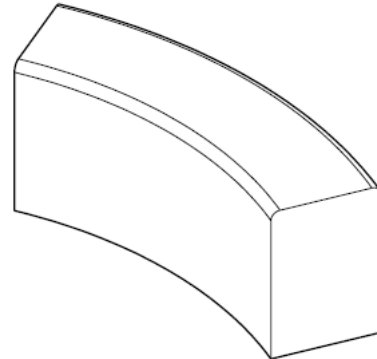

#### Colour: Available in standard colours

- White: WH03, WH06
- Light Grey: LG01, LG02, LG05
- Dark Grey: BL02
- Black: BL03
- Buff: YL01
- Other colours available on request

#### Finish:

- Concrete: Light Acid Etched
- Timber: N/A
- Other finishes available on request

#### Fixing: Surface Fixed

Unit should be placed on finished surface, using appropriate lifting equipment, no additional fixing required.

#### Packing:

Banded & protected. 1 unit per pallet. Unit to be removed from the pallet before installation.

#### Standard Shipping:

Dedicated delivery or pallet service available by request

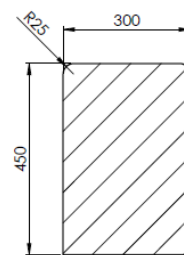
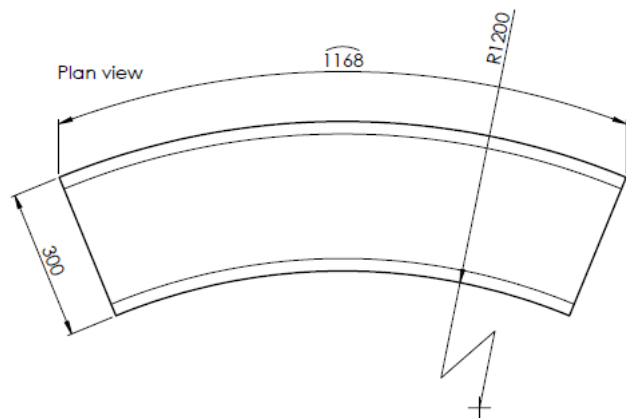

SCALE 1:8  
section through

#### Technical Details:

- Length: 1168mm
- Depth: 300mm
- Height: 450mm
- Weight: 378Kg